

Model EC-25 Extended Coverage Area Density Sprinklers 25.2 K-factor

General Description

The Model EC-25 Extended Coverage Upright Sprinklers (Ref. Figure 1) are "Control-Mode Extended Coverage Sprinklers" having a nominal K-factor of 25.2. Their use is especially advantageous as a means of decreasing the number of required sprinklers to protect occupancies requiring an area/density application of water.

These sprinklers offer maximum coverage areas of 14 feet by 14 feet (196 sq. ft.) which is almost double that of standard coverage sprinklers used for similar applications.

The EC-25 Sprinklers comply with the criterion for the protection of retail stores as described in the 2002 edition of NFPA 13, Section 12-7.2

Where the FM Approval is utilized, the EC-25 has successfully undergone full-scale fire testing at FM for use under obstructed ceiling conditions for area/density design applications. **This testing has demonstrated that the Model EC-25 at its extended coverage spacings can be installed using all other standard coverage sprinkler criteria. As such, they are acceptable for all currently recognized area/density applications.**

IMPORTANT

Always refer to Technical Data Sheet TFP700 for the "INSTALLER WARNING" that provides cautions with respect to handling and installation of sprinkler systems and components. Improper handling and installation can permanently damage a sprinkler system or its components and cause the sprinkler to fail to operate in a fire situation or cause it to operate prematurely.

Applications for the Model EC-25 Sprinklers are expanding beyond the current testing. For information regarding additional research fire tests that may be acceptable to an Authority Having Jurisdiction please contact the Technical Services Department.

WARNINGS

The Model EC-25 Sprinklers described herein must be installed and maintained in compliance with this document, as well as with the applicable standards of the National Fire Protection Association, in addition to the standards of any other authorities having jurisdiction (e.g., FM Global). Failure to do so may impair the performance of these devices.

The owner is responsible for maintaining their fire protection system and devices in proper operating condition. The installing contractor or sprinkler manufacturer should be contacted with any questions.

Sprinkler Identification Number

SIN TY9128 - (Upright K=25.2)

Technical Data

Approvals

FM Approved. UL and C-UL Listed. (Approvals only apply to the service conditions indicated in the Design Criteria section.)
NYC under MEA 355-01-E.

Maximum Working Pressure

175 psi (12,1 bar)

Pipe Thread Connection

1 inch NPT or ISO 7-R1

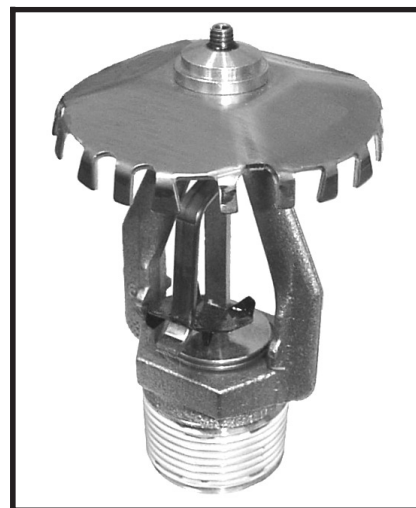

Discharge Coefficient

K = 25.2 GPM/psi^{1/2}
(362,9 LPM/bar^{1/2})

Temperature Ratings

165°F/74°C or 214°F/101°C

Finish

Natural Brass

Physical Characteristics

Frame	Brass
Deflector	Copper
Compression Screw	
	Stainless Steel
Hook	Monel
Strut	Monel
Link Assembly	Solder, Nickel
Button	Brass
Sealing Assembly	
	Beryllium Nickel w/Teflon [†]
Ejection Spring	Inconel
Deflector Nut	Brass

Patents

U.S.A. Patent Number 4,580,729.

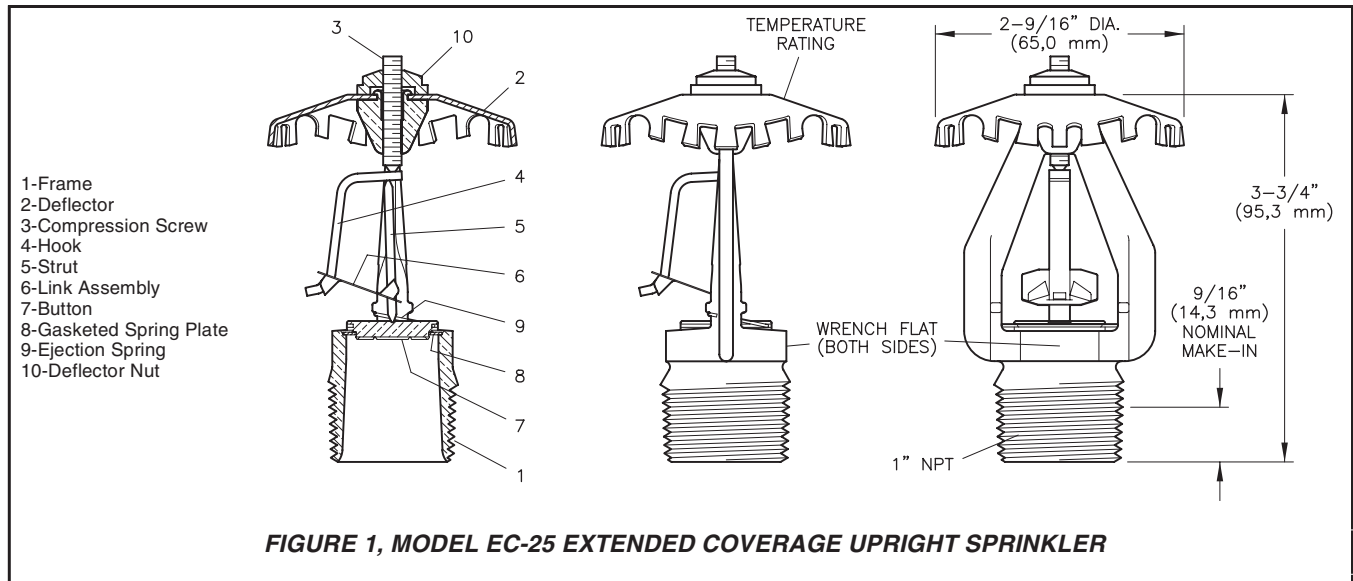

Operation

The fusible link assembly is comprised of two link halves that are joined together by a thin layer of solder. When the rated temperature is reached, the solder melts and the two link halves separate allowing the sprinkler to activate and flow water.

Design Criteria

FM APPROVAL CRITERIA

The Model EC-25 Extended Coverage Upright Sprinklers (SIN TY9128) are FM Approved to be utilized in accordance with the following guidelines:

1. Application: The Model EC-25 Extended Coverage Upright Sprinklers may be used to protect any occupancy for which there is an area/density design criterion up to 11.2 K-Factor standard spray (control-mode area/density) sprinklers specified in FM Global Data Sheets. The Model EC-25 Sprinklers are not approved for use in control-mode specific application (e.g. large-drop) or suppression-mode (ESFR) protection designs.

2. Hydraulic Design: Area/density designs should be the same as those for 11.2 K-Factor standard spray (control-mode area/density) sprinklers when a separate 11.2 K-Factor standard spray (control-mode area/density) sprinkler design criteria is provided. Otherwise use the same design criteria as 5.6 or 8.0 K-Factor standard spray (control-mode area/density) sprinklers. The minimum design pressure is 7 psi (0,5

bar), and a K-factor of 25.2 (363 metric) is to be used for hydraulic calculations. As for all area/density sprinklers, the hydraulic design for the Model EC-25 sprinklers should be based on the design density applied over the actual area of coverage per sprinkler.

For example: when sprinkler spacing is 14 feet by 12 feet - 6 inches (4,3 x 3,8 m) or 175 ft² (16,3 m²), and the design density is 0.6 gpm/ft² (24,4 mm/m), the sprinkler design flow rate is 105 GPM (397 LPM) and the required design pressure is 17.4 psi (1,2 bar).

3. System Type: Wet-pipe, dry-pipe, or preaction systems are acceptable.

4. Sprinkler Spacing: The maximum area of coverage per sprinkler is 196 sq. ft. (18,2 sq. m). The minimum area of coverage per sprinkler is 100 sq. ft. (9,3 sq. m). The maximum distance between sprinklers is 14 feet (4,3 m). The minimum distance between sprinklers is 10 feet (3,05 m).

Exception: When a wall or obstruction makes a minimum spacing of 10 feet (3,05) impossible between the line of sprinklers along the wall and the next adjacent line of sprinklers, the minimum distance from the sprinklers located along the wall or obstruction to the sprinklers located on the adjacent row can be a minimum of 7 feet (2,13 m). In this case the sprinklers located along the wall or obstruction must be hydraulically calculated for a 100 sq. ft. (9,3 sq. m) coverage area or their actual coverage area, whichever is greater.

5. Sprinkler Location: Locate sprinklers with respect to the ceiling/roof in accordance with Section 4-6.4 of FM Global Data Sheet 2-8N.

Exception: Exception #4 to Section 4-6.4.1.2 of FM Global Data Sheet 2-8N does not apply to extended coverage control mode sprinklers. For obstructed construction, when the structural members are deeper than 12 inches (300 mm) and spaced less than 42 inches (1050 mm) on center, install sprinklers in every bay.

6. Obstructions: Follow the obstruction requirements for standard spray (control-mode area/density) sprinklers in Section 4-6.5 of FM Global Data Sheet 2-8N.

7. Other Details: All other design details should be in accordance with FM Global Data Sheet 2-8N, as well as any other applicable FM Global Data Sheet.

UL AND C-UL LISTING CRITERIA

The Model EC-25 Extended Coverage Upright Sprinklers (SIN TY9128) are UL and C-UL Listed for installation in accordance with the extended coverage upright spray sprinkler requirements of NFPA 13, or other applicable NFPA standards, when used in conjunction with the following guidelines:

- Suitable for the protection of extra hazard and high-piled storage occupancies where area/density design criterion are provided.
- Suitable for "unobstructed" or "non-combustible obstructed" construction.
- The Model EC-25 Sprinklers having been specifically tested and listed for noncombustible obstructed construction are suitable for use within trusses or bar joists having non-combustible web members greater

than 1 inch (25.4 mm) when applying the 4 times obstruction criteria rule defined under "Obstructions to Sprinkler Discharge Pattern Development".

- The maximum area of coverage per sprinkler is 196 sq. ft. (18,2 sq. m). The maximum distance between sprinklers is 14 feet (4,3 m). The minimum distance between sprinklers is 8 feet (2,44 m).
- The minimum flow requirement is to be based on the design density applied over the actual area of coverage per sprinkler.

For example: when sprinkler spacing is 14 feet by 12 feet - 6 inches (4,3 x 3,8 m) or 175 ft² (16,3 m²), and the design density is 0.6 gpm/ft² (24,4 mm/m), the sprinkler design flow rate is 105 GPM (397 LPM) and the required design pressure is 17.4 psi (1,2 bar).

- The minimum clearance between the deflector and the top of storage is 36 inches (0,9 m). For clearances of 36 inches (0,9 m) up to 48 inches (1,21 m), the minimum design pressure is 22 psi (1,52 bar). For clearances of 48 inches (1,21 m) and greater, the minimum design pressure is established by the minimum flow requirement (however, the pressure can never be less than 7 psi).
- The ordinary and intermediate temperature rated EC-25 Sprinklers have been investigated for use in high-piled storage occupancies at the hydraulic demand normally associated with high temperature sprinklers. As such, the EC-25 sprinklers are listed storage sprinklers having a K-factor greater than 11.2 and having ordinary and intermediate temperature ratings (i.e., 165F and 214F). Consequently, the EC-25 Sprinklers, in accordance with the 2002 edition of NFPA 13, may be used in conjunction with the density curves for high temperature sprinklers specified in Chapter 12 of the 2002 edition of NFPA 13.

Installation

The Model EC-25 Upright Sprinklers are to be installed in accordance with the following instructions:

NOTE

Damage to the fusible Link Assembly during installation can be avoided by handling the sprinkler only by the frame arms only and by using the appropriate sprinkler wrench. Do not grip or apply any force to the Fusible Link

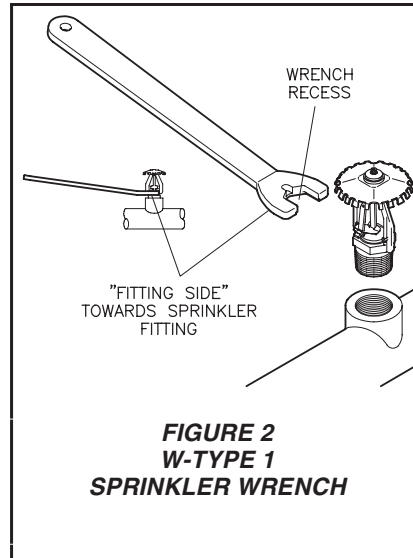

**FIGURE 2
W-TYPE 1
SPRINKLER WRENCH**

Assembly. Damaged sprinklers must be replaced immediately.

A leak tight 1 inch NPT sprinkler joint should be obtained with a torque of 20 to 30 ft.lbs. (26,8 to 40,2 Nm). Higher levels of torque may distort the sprinkler inlet with consequent leakage or impairment of the sprinkler.

Step 1. The EC-25 Sprinkler must be installed in the upright position.

Step 2. With pipe thread sealant applied, hand tighten the sprinkler into the sprinkler fitting. Do not apply any force to the Link Assembly, and handle the EC-25 Sprinkler only by the Frame arms.

Step 3. Wrench tighten the EC-25 Sprinkler using only the W-Type 1 Sprinkler Wrench (Ref. Figure 2) and by fully engaging (seating) the wrench on the sprinkler wrench flats.

Step 4. After installation, inspect the Link Assembly of each EC-25 Sprinkler for damage. In particular, verify that the Link Assembly and Hook are positioned as illustrated in Figure 1, and that the Link Assembly has not been bent, creased, or forced out of its normal position in any way.

Damaged sprinklers must be replaced immediately.

Care and Maintenance

The Model EC-25 must be maintained and serviced in accordance with the following instructions:

NOTE

Before closing a fire protection system main control valve for maintenance work on the fire protection system that it controls, permission to shut down the affected fire protection systems must be obtained from the proper authorities and all personnel who may be affected by this action must be notified.

Sprinklers that are found to be leaking or exhibiting visible signs of corrosion must be replaced.

Automatic sprinklers must never be painted, plated, coated, or otherwise altered after leaving the factory. Modified or over-heated sprinklers must be replaced.

Care must be exercised to avoid damage - before, during, and after installation. Sprinklers damaged by dropping, striking, wrench twist/slippage, or the like, must be replaced.

The owner is responsible for the inspection, testing, and maintenance of their fire protection system and devices in compliance with this document, as well as with the applicable standards of the National Fire Protection Association (e.g., NFPA 25), in addition to the standards of any other authorities having jurisdiction. The installing contractor or sprinkler manufacturer should be contacted relative to any questions.

It is recommended that automatic sprinkler systems be inspected, tested, and maintained by a qualified Inspection Service in accordance with local requirements and/or national code.

Limited Warranty

Products manufactured by Tyco Fire Products are warranted solely to the original Buyer for ten (10) years against defects in material and workmanship when paid for and properly installed and maintained under normal use and service. This warranty will expire ten (10) years from date of shipment by Tyco Fire Products. No warranty is given for products or components manufactured by companies not affiliated by ownership with Tyco Fire Products or for products and components which have been subject to misuse, improper installation, corrosion, or which have not been installed, maintained, modified or repaired in accordance with applicable Standards of the National Fire Protection Association, and/or the standards of any other Authorities Having Jurisdiction. Materials found by Tyco Fire Products to be defective shall be either repaired or replaced, at Tyco Fire Products' sole option. Tyco Fire Products neither assumes, nor authorizes any person to assume for it, any other obligation in connection with the sale of products or parts of products. Tyco Fire Products shall not be responsible for sprinkler system design errors or inaccurate or incomplete information supplied by Buyer or Buyer's representatives.

IN NO EVENT SHALL TYCO FIRE PRODUCTS BE LIABLE, IN CONTRACT, TORT, STRICT LIABILITY OR UNDER ANY OTHER LEGAL THEORY, FOR INCIDENTAL, INDIRECT, SPECIAL OR CONSEQUENTIAL DAMAGES, INCLUDING BUT NOT LIMITED TO LABOR CHARGES, REGARDLESS OF WHETHER TYCO FIRE PRODUCTS WAS INFORMED ABOUT THE POSSIBILITY OF SUCH DAMAGES, AND IN NO EVENT SHALL TYCO FIRE PRODUCTS' LIABILITY EXCEED AN AMOUNT EQUAL TO THE SALES PRICE.

THE FOREGOING WARRANTY IS MADE IN LIEU OF ANY AND ALL OTHER WARRANTIES EXPRESS OR IMPLIED, INCLUDING WARRANTIES OF MERCHANTABILITY AND FITNESS FOR A PARTICULAR PURPOSE.

Ordering Procedure

When placing an order, indicate the full product name. Please specify the Sprinkler Identification Number (SIN), quantity, and temperature rating. Refer to the Price List for complete listing of Part Numbers.

Contact your local distributor for availability.

Sprinkler Assemblies:

Specify: (specify temperature rating), natural brass, Model EC-25 (TY9128) Extended Coverage Upright Sprinkler, P/N (specify).

165°F/74°C P/N 58-450-1-165
 214°F/101°C P/N 58-450-1-214

“Special Order”

Sprinkler Assemblies with ISO 7/1 Thread Connections:

Specify: (specify temperature rating), natural brass, Model EC-25 (TY9128) Extended Coverage Upright Sprinkler with thread connection per ISO 7/1, P/N (specify).

165°F/74°C P/N 58-451-1-165
 214°F/101°C P/N 58-451-1-214

Sprinkler Wrench

Specify: W-Type 1 Sprinkler Wrench, P/N 56-872-1-025.